

Electromagnetic dancer EDR 10

With processor controlled Easy-Driver EDD V5

The electromagnetic dancer is a high-precision tension regulator, e.g. for unwinding, winding and rewinding processes for wires and fibers.

Due to the patented electromagnetic force method of the electromagnetic dancer, the traction force always remains constant.

All the necessary functions for tension control are already included in the associated electronics, the EDD:

- Tension regulator
- Dancer position controller
- RPM control for a drive engine
- Dancer position output with break detection

The parameterization of the dancer position controller and the tension adjustment of the electromagnetic dancer can be done serially via USB or RS485. Alternatively, analog inputs are also available for the tension setting.

A comfortable setting is possible with the software SUMMI easy or SUMMI pro or with the operating unit CMC.

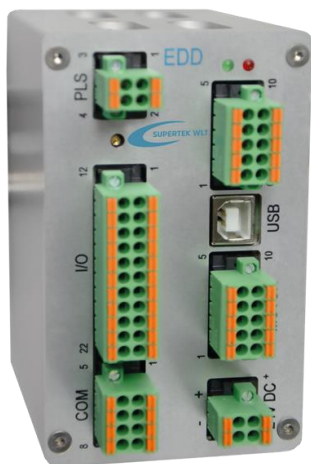

Description	Item no.:
Set consisting of dancer EDR 10 and Easy-Driver EDD V5	WEDR10EDDV501
Connecting line EDR with EDD	WLTGEDD3M WLTGEDD5M WLTGEDD10M
3m	
5m	
10m	
Pulleys	On request
Software SUMMI <i>easy</i>	WSUMMIEASY
Software SUMMI <i>pro</i>	WSUMMIPRO
Compact operator and control unit CMC	WCMC01

Electromagnetic dancer EDR 10

Tension range	2mN to 1000mN
Single wound	
Dancer force	4mN to 2000mN
Generation of force	electromagnetic
Dancer force position independent	Yes
Position measurement, integrated	Yes, contactless
Dancer stroke angle	40°
Dancer stroke with standard-arm	40mm
Weight	1,8kg
Operating temperature	10 – 40°C
Mountage	See page 2
Electronics	EDD
Pulleys	optional

Processor controlled Easy-Driver EDD V5

Rated voltage	24V DC
Current, max.	1A
Mountage	Hat rail 35mm
Dimensions: w, h, d	64, 105, 113mm
Dancer position output	0-10V
Dancer position controller	Ja, PI-Controller
Correcting variable as rotational speed of motor	0-10V pulse/direction
Potential-free outputs	4
Output signal dancer position up	Yes
Output signal dancer position down	Yes
Adjustment of dancer force	automatic
Tension setting analog	Yes, 2X 0-10V
Tension setting digital	Yes, RS485, USB
Tension setting	in 1mN steps
Parameterization, setting, operation:	
Software SUMMI <i>easy</i>	Yes
Software SUMMI <i>pro</i>	Yes
Operator and control unit CMC	Yes

Mountage, Electromagnetic dancer EDR 10

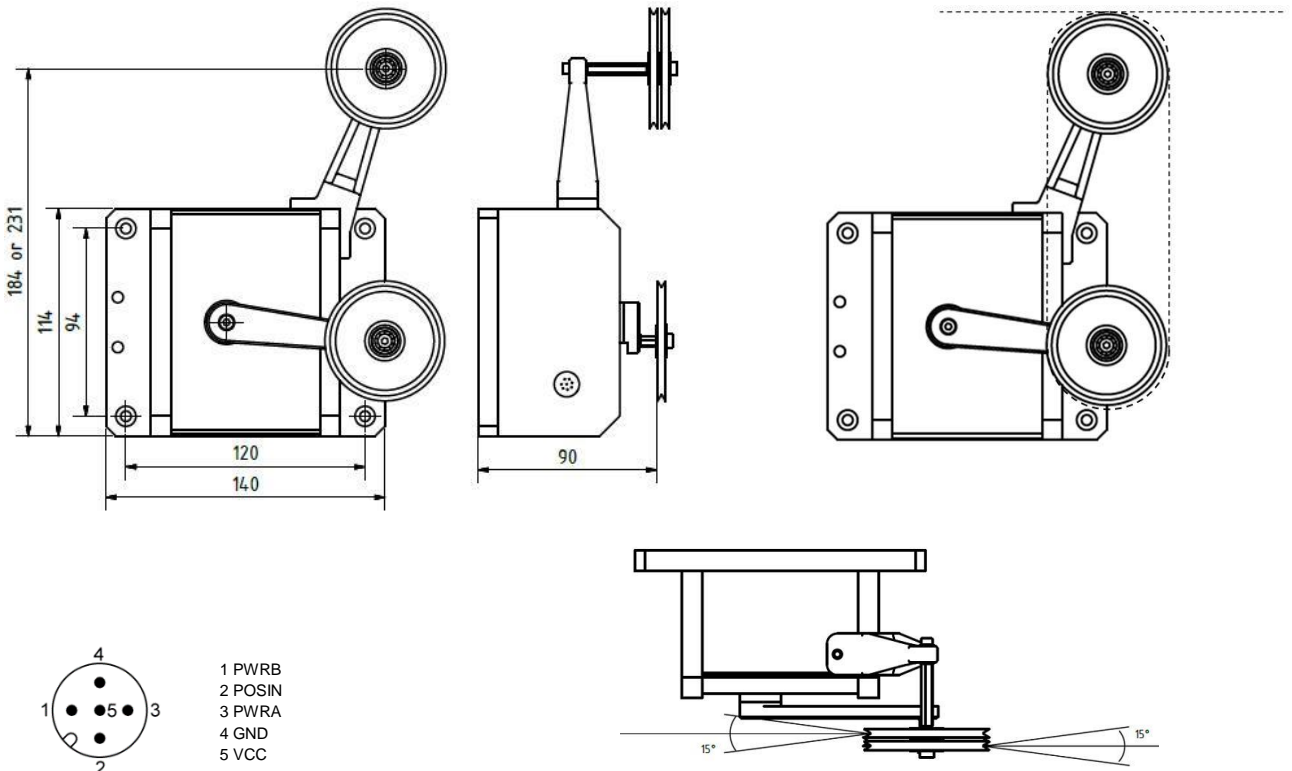

Connection diagram, Processor controlled Easy-Driver EDD V5

